



SMD601 Plus

The most Sensitive Multi-Zone Metal Detector for Law Enforcement and Correctional Facilities



**NEW
REFERENCE STANDARD
IN SENSITIVITY**



- Most Sensitive WTMD, fully compliant with the NIJ-0601.02 and NIJ-0601.03 Standards
- Very Accurate Pinpointing of individual and multiple metal targets
- Integrated Correctional Profiling System (optional)
- Exceptional Immunity to environmental interferences
- Unmatched Reliability



GSA Contract Holder

www.ceia-usa.com

Threat Detection through Electromagnetics

SMD601 Plus

Most Sensitive Multi-Zone Metal Detector



Most Sensitive Multi-Zone Metal Detector

The SMD601 series Walk-Through Metal Detectors include two distinct models, **SMD601** and **SMD601 Plus**

Both of them comply with the strictest Law Enforcement Standard for WTMDs (i.e. NIJ-0601.02). The well know SMD601 model is the best high sensitivity equipment available in the market today and it has been selected and adopted by the most prestigious Law Enforcement Institutions.

The new SMD601 Plus further extends the detection sensitivity of the SMD601 to metal threats previously considered undetectable due to their minimal dimensions and metal composition similar to the ones specified in the new NIJ-0601.03 Standard.

Fully compliant with the NIJ-0601.02 and NIJ-0601.03 Standards

SMD601 model



- Handgun Zn
- Handgun St
- Handgun Al

NIJ-LO level
LARGE OBJECT SIZE (Handguns)



NIJ-M0 level
MEDIUM OBJECT SIZE (Knives)

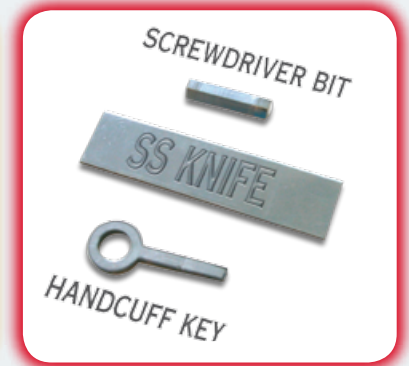

NIJ-S0 level
SMALL OBJECT SIZE (small, hard-to-find items)

SMD601 Plus model



Plus

same as SMD601



- Disposable Razor Blades
- Special metal items (e.g. AISI 300 series Stainless Steel)
- Bullets

Ultra-High Sensitivity capability
(examples of additional detectable targets)

The Reference Standard in Detection Capability

SMD601 Plus detects even the smallest metal items **anywhere on or in the body**

The SMD601 Plus is a very high sensitive Walk-Through Metal Detector. **An absolute must when the detection of extremely small metal masses is required** on the body or even if hidden in body cavities.

A full-height light bar displays the location of the detected metal masses in transit. This results in **rapid identification of threats and a reduction or elimination of the need for manual searches.**



HIGH RESOLUTION AND PRECISION

- Very accurate pinpointing of individual and multiple metal targets



VERY HIGH SENSITIVITY

- Quick, accurate analysis of all parts of the body of people in transit, from the shoe level to the crossbar



SECURITY LEVELS

- Built-in programs to screen visitors and staff for weapons and contraband

Advanced Alarm Indication



PROGRAMMABLE DISPLAY BARS

- Entrance and Exit Multi-Zone Display Bars each programmable as entry pacing and/or localization lights



FLEXIBLE SOUND SYSTEM

- Flexible Acoustic Alarm Signaling System:
 - 10 Continuous and Pulsed Tones
 - 34 Special Sounds
- 10 Acoustic Intensity Levels programmable from 0 up to 90 dBA at 1 m



BIDIRECTIONAL COUNTER

- High Precision Transit Counter:
 - In-Bound Transits
 - Out-Bound Transits
 - Alarm Rate

An accurate and comprehensive alarm system allows the best use of Metal Detector. Optical indicators are fully programmable, both gate sides can indicate either separately or simultaneously vertical transit zones of detected threats and also be configured as traffic lights to regulate the access of the people being screened.

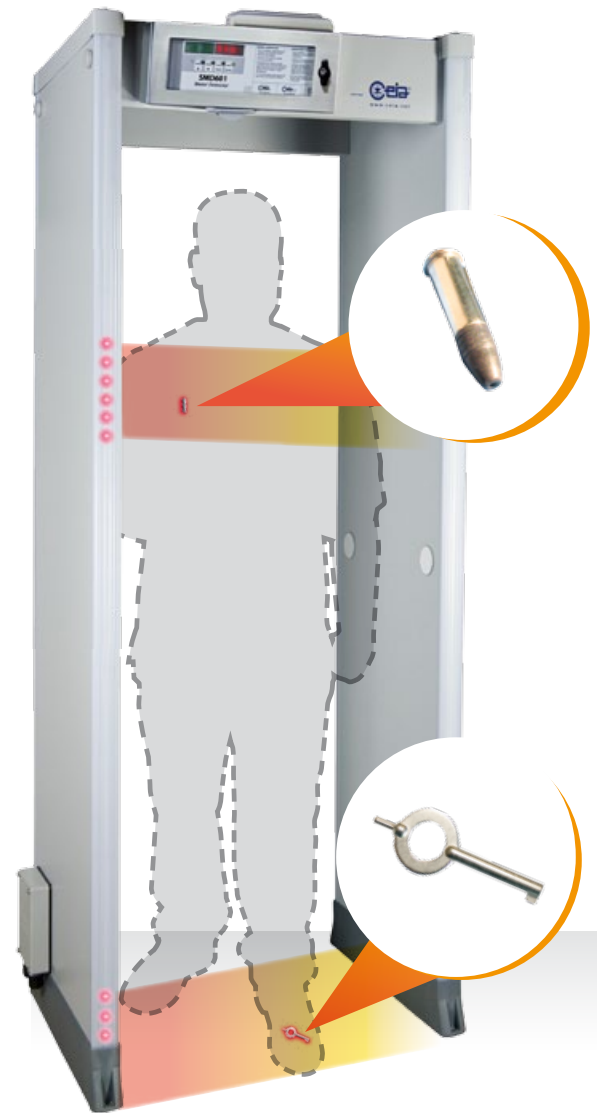

VIEW OF THE SMD601 PLUS WITH ANTI-VANDALISM AND ANTI-TAMPERING PROTECTION OPTION



ENTRY PACING LIGHTS

SMD601 Plus

Most Sensitive Multi-Zone Metal Detector



Comprehensive Security Features



- Over 40 built-in Security Programs

- Up to 22 pre-programmed Security Programs
- Up to 20 user programmable Security Programs



- Chip Card system for fast, simple and secure parameter changes (i.e. alarm volume and tone, counter reading, etc...) and Security Level Selection

A feature of CEIA's Metal Detectors is a chip-card system that allows the Head of Security to set the Security Level quickly, reliably and discreetly, without any programming operation on the detector itself.

Communication Capabilities

TYPE OF OPERATION	Ethernet	Wi-Fi	USB	Infrared	Bluetooth	RS-232
Maintenance	○	○	○		●	●
Remote Control	○	○		●	●	●
Remote Data collection	○	○				

● STANDARD ○ OPTION

Model Configuration

Features	SMD601/PZPlus
Fully compliant with and exceeding the NIJ-0601.02 Standard	●
Additional Ultra-High Sensitivity (NIJ-0601.03 Standard)	●
2 display bars programmable as zone indicators and/or pacing lights	●
Dual Side 20 localization zones	●
Powered by safe low voltage DC	●
Chip Card Reader	●
One Touch Automatic Self Installation (OTS)	●
Bluetooth, infrared and RS-232 communication	●
Password and hardware key access protection	●
Anti-tamper on/off switch	●
High precision transit counter	●
Programmable Random Alarm capability	●
Correctional Profiling System	○
Integrated web-server & logger (includes Ethernet and USB interface)	○
Integrated video camera (lobby applications) with MDAR software	○
Weather resistant protection	○
Anti-vandalism, anti-tampering protection	○
IP65 protection (includes weather resistant and anti-vandalism options)	○
Embedded battery charger and under-voltage protection	○
Long life crossbar battery back-up	○

● STANDARD ○ OPTION

Dimensions

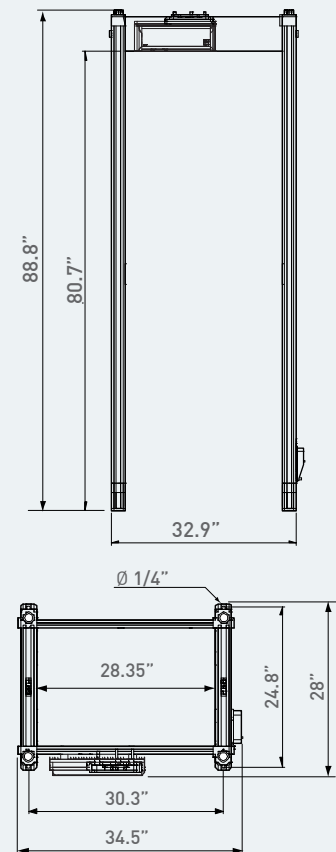

Correctional Profiling System (option # 1D/2DREADER/P)



NIJ compliant screening of people with or without implanted metal objects

1



1 A registered user presents his badge to the reader.

2a



2a The person transits through the Metal Detector.

The Metal Detector ignores non-removable metal objects such as prosthetics or shrapnel present inside the person.

2b



2b The person transits through the Metal Detector.

The Metal Detector shows the threat objects.

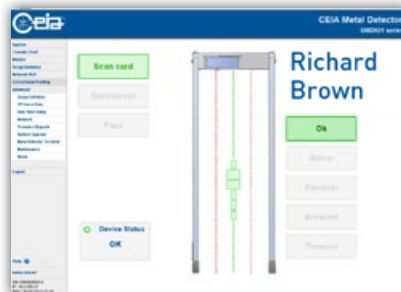

➤ This option requires the installation of the integrated web-server & logger.

➤ Alarm signaling may be shown on a PC or tablet web browser

APSiM3Plus Integrated Web-server & Logger (option # APSiM3Plus/P)



- Monitor the status of Metal Detector network in real time
- Remotely control and verify the security level



- Report on number of people screened and alarm rates automatically
- No server or specialized client software required, only a web browser
- Zero configuration network for simple setup

- 2 x Ethernet 100base-TX
- Wi-Fi - 802.11 b/g

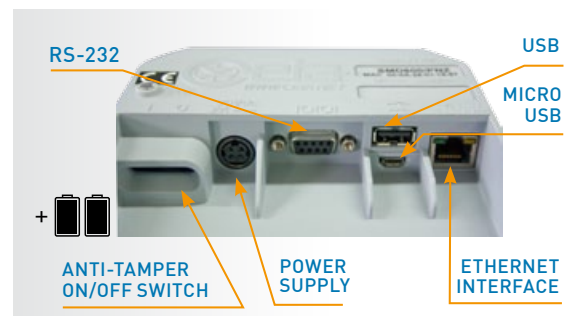

SMD601 Plus

Most Sensitive Multi-Zone Metal Detector



Additional Options and Upgrade Kits

➤ Integrated video camera with MDAR software

SMD601 series can be equipped with an embedded camera to record people in transit. The kit includes the camera with mechanical support, the adapter crossbar and the connection cable. This option requires the installation of the integrated web-server & logger.

Part # 54253



MDAR, VIDEO RECORDER AND INSTANT ALARM PLAYER



➤ Weather resistant protection

Kit for upgrading the standard version to outdoor applications according to IEC 60950-22; this kit includes shelters, crossbars, protection covers for power supply and waterproof mains power supply adapter.

Part # 55630



➤ Anti-vandalism, anti-tampering protection

This option includes stainless steel control unit, waterproof mains power supply adapter, protection covers for power supply and antenna connection compartments, equipped with screws requiring tools for removal.



➤ IP65 protection

This option includes the Weather Resistant and Anti-vandalism kits. Part # 55631

➤ Long life crossbar battery back-up

Crossbar battery back-up in stainless steel case. Provides up to 6 hours of autonomous working time.

Part # 55681

UP TO 6 HOURS TYPICAL CONTINUOUS OPERATION WITH SMD601 PLUS



➤ Embedded battery charger and under-voltage protection

Anti-tamper on/off switch, RS-232 interface, battery charger with 12 hours mains disconnection diagnostic alarm.

Part # APSM2Plus/P



Accessories

➤ Chip cards

Chip cards for simple and secure selection of Security Levels and parameter setting. List of chip-cards available on request.



➤ RCU2

Control unit for full remote access, including alarm signalling and programming of CEIA Metal Detectors.
Part # RCU2



VISUAL ALARM WITH ZONE INDICATION

➤ MBSU-2

Independent, compact size, long life power supply in weatherproof stainless steel case, with embedded fast charger:

- Up to 9 hours typical (6 hours minimum) continuous operation with SMD601 Plus
 - 5 hours typical charging time.
- Part # MBSU-2



➤ MD-Scope

Powerful, PC based installation and service Software. Includes oscilloscope and terminal functionality. Part # MD-SCOPE2



➤ IRC-1

Infrared Remote Controller for wireless remote programming of the control unit. Part # 47180



➤ Metal Detector Divesting Table FOR MANAGEMENT OF PERSONAL METAL BELONGINGS

- Standard length: 24" (Part # 18074)
- Extended length: 47" (Part # 39491)



➤ Upper connection module

This extension cable allows the connection of power supply and serial communication to personal computers or CEIA accessories, such as RCU-2. Part # 46650

➤ RRU

Remote relay unit (RRU) to repeat the detection alarms of the gate through a relay contact. The RRU module can be used for integration of the Metal Detector in interlocked door systems. Part # RRU

➤ Test samples kit

- Part # NIJ-0601.02-SK: complete test samples kit for NIJ-0601.02 compliance verification.
- Part # EMD-SK-NIJ-SO/MO: test samples kit for NIJ-0601.02 detection capability verification.
- Part # EMD-SK-NIJ-CL2/3: test samples kit for NIJ-0601.03 detection capability verification.

➤ Waterproof mains power supply

100W IP67 power supply for outdoor applications. It is provided with flanges for simple installation. Part # 43564



SMD601 Plus

Most Sensitive Multi-Zone Metal Detector



Specifications

KEY FEATURES	Ultra High Sensitivity	
	Fully compliant with, and exceeding, the NIJ-0601.02 Standard	
	20 High Precision localization zones	
	High precision bidirectional counter with automatic rescreening compensation	
	Chip Card capability for fast, simple, and secure programming	
	Random alarm capability programmable from 0% to 100%	
	Exceptional Immunity to external interferences	
	Can be combined with the Network based CEIA Profiling System for further sensitivity enhancement by compensating non-removable personal metal items	
	Powered by safe low voltage DC	
	Standard Interfaces: RS-232, Bluetooth, Infrared	
Other available interfaces: Wi-Fi, Ethernet, USB		
QUALITY	Continuous self diagnostic system	
	Proven reliability	
	No periodic re-calibration and preventive maintenance required	
	No scheduled maintenance	
	Fully digital design	
WALK-THROUGH GATE STRUCTURE	State-of-the-art, robust and washable panels	
	Protected against aging, weather and wear	
CENTRAL CONTROL UNIT	Ergonomic and robust design	
	High visibility alphanumeric display and programming keyboard	
	Made of advanced plastics or stainless steel and anti-vandalism construction (option)	
	Access to the front panel protected by hardware key and two levels of passwords	
ALARM SIGNALLING	VISUAL SIGNALS	Multi-zone display bar for "height on person" localization
		2 light bars with selectable entry/exit and pacing indication
		Green and red metering signals proportional to the mass of the detected target
	AUDIO SIGNALS	10 selectable continuous and pulsed tone plus 34 special tones
10 selectable sound intensities ranging from 0 to 90 dbA at 1m		
TYPE OF SIGNALLING	VISUAL	Fixed or proportional to the mass in transit - visible from 6m under lighting of 4000lux
	VISUAL ZONE INDICATION	20 distinct zones
PROGRAMMING	Over 40 built-in security programs	
	Remote via RS-232, Infrared Remote Control Unit, Bluetooth™ or Ethernet 10/100 base T interface	
	SECURITY LEVEL	International Standard (IS) command
		Chip card
	Local by Control Unit alphanumeric display and keyboard	
Programming and chip-card access protected by user and super-user passwords		
OPERATIONAL FEATURES	Quick reset time as short as 0.2 seconds for high throughput rate	
	Very high detection speed (up to 50 ft/sec.)	
	Built-in operational and technical functional verification	
	One-touch key reading of inbound, outbound and Security Level Data	
INSTALLATION DATA	Automatic synchronisation between two or more metal detectors with distance as close as 12" (30 cm) without the use of external cables	
	Built-in floor sensitivity adjustment function	
	Automatic Installation function (OTS)	
SHIPPING DATA	Dimensions (WxDxH): 92" x 11.4" x 31.5" (2340 mm x 290 mm x 800 mm)	
	Weight: 163 lbs (74 kg)	

Environmental Data

- **POWER SUPPLY** : 100...240V~ -10/+15%, 47...63Hz, 70 VA max
- **OPERATING TEMPERATURE**: -4°F to 158°F (-20°C to +70°C)
-34.60°F to 158°F upon request (-37°C to +70°C)
- **STORAGE TEMPERATURE**: -34.60°F to 158 °F (-37°C to +70°C)
- **RELATIVE HUMIDITY**: 0 to 95% (without condensation)

Certification and Compliance

- Complies with and exceeds the applicable Standards for Law Enforcement and Correctional Facilities
- Fully compliant with, and exceeding, the NIJ-0601.02 Standard
- Compliant with the applicable electromagnetic Standards on Human Exposure and Pacemaker Safety
- Compliant with applicable International Standards for electrical safety and EMC
- Harmless to magnetic media (floppy disks, tapes, etc.)

Comprehensive support

CEIA PROVIDES FULL OPERATIONAL AND TECHNICAL TRAINING SUPPORT BY CERTIFIED PERSONNEL EITHER AT CEIA FACILITY OR AT CUSTOMER PREMISES



- phone technical support
- in-house and on-site repair/ services
- standard and custom training



CEIA USA Ltd - 9155 Dutton Drive, Twinsburg, OH 44087
Phone: (330) 405 3190 - Fax (330) 405 3196 - e-mail: security@ceia-usa.com

DP060K0057V1000US-60067

www.ceia-usa.com

Call Toll-Free 888-532-CEIA

© 2012 CEIA USA, Ltd. All rights reserved. CEIA USA reserves the right to make changes, at any moment and without notice, to the models (including programming), their accessories and options, to the prices and conditions of sale